



The American Society of  
Mechanical Engineers

A N A M E R I C A N N A T I O N A L S T A N D A R D

# PLIERS: WIRE TWISTER

**ASME B107.18-2003**  
(Revision of ASME B107.18M-1998)

Date of Issuance: September 5, 2003

This Standard will be revised when the Society approves the issuance of a new edition. There will be no addenda issued to this edition.

ASME issues written replies to inquiries concerning interpretations of technical aspects of this Standard. Interpretations are published on the ASME Web site under the Committee Pages at <http://www.asme.org/codes/> as they are issued.

ASME is the registered trademark of The American Society of Mechanical Engineers.

This code or standard was developed under procedures accredited as meeting the criteria for American National Standards. The Standards Committee that approved the code or standard was balanced to assure that individuals from competent and concerned interests have had an opportunity to participate. The proposed code or standard was made available for public review and comment that provides an opportunity for additional public input from industry, academia, regulatory agencies, and the public-at-large.

ASME does not "approve," "rate," or "endorse" any item, construction, proprietary device, or activity.

ASME does not take any position with respect to the validity of any patent rights asserted in connection with any items mentioned in this document, and does not undertake to insure anyone utilizing a standard against liability for infringement of any applicable letters patent, nor assume any such liability. Users of a code or standard are expressly advised that determination of the validity of any such patent rights, and the risk of infringement of such rights, is entirely their own responsibility.

Participation by federal agency representative(s) or person(s) affiliated with industry is not to be interpreted as government or industry endorsement of this code or standard.

ASME accepts responsibility for only those interpretations of this document issued in accordance with the established ASME procedures and policies, which precludes the issuance of interpretations by individuals.

No part of this document may be reproduced in any form,  
in an electronic retrieval system or otherwise,  
without the prior written permission of the publisher.

The American Society of Mechanical Engineers  
Three Park Avenue, New York, NY 10016-5990

Copyright © 2003 by  
THE AMERICAN SOCIETY OF MECHANICAL ENGINEERS  
All rights reserved  
Printed in U.S.A.

# CONTENTS

Foreword .....	iv
Committee Roster .....	v
Correspondence With the B107 Committee .....	vi
<b>1 Scope .....</b>	<b>1</b>
<b>2 Classification .....</b>	<b>1</b>
<b>3 Normative References .....</b>	<b>1</b>
<b>4 Definitions .....</b>	<b>1</b>
<b>5 Requirements .....</b>	<b>1</b>
<b>6 Tests .....</b>	<b>3</b>
<b>7 Safety Requirements and Limitations of Use .....</b>	<b>7</b>
<b>8 Designations .....</b>	<b>7</b>
<b>Figures</b>	
1 Nose Design, Pliers, Wire Twister, 6 in. ....	3
2 Nose Design, Pliers, Wire Twister, 152 mm. ....	4
3 Nose Design, Pliers, Wire Twister, 9 in. and 12 in. ....	5
4 Nose Design, Pliers, Wire Twister, 229 mm and 305 mm. ....	6
5 Pliers, Wire Twister, With Side Cutter in Locked Position. ....	7
<b>Tables</b>	
1 Dimensions of Pliers, Wire Twister, With Side Cutter. ....	2
1M Dimensions of Pliers, Wire Twister, With Side Cutter. ....	2
2 Wire Cut Test Parameters .....	7
2M Wire Cut Test Parameters .....	7

## FOREWORD

The American National Standards Committee B107, Socket Wrenches and Drives, under sponsorship of The American Society of Mechanical Engineers, was reorganized as an ASME Standards Committee and its title was changed to Hand Tools and Accessories. In 1996 its scope was expanded to address safety considerations.

The purposes of this Standard are to define general and dimensional data and safety considerations specifically applicable to wire twisting pliers and to specify test methods to evaluate performance relating to the defined requirements.

This Standard is a revision of ASME B107.18M-1996 Pliers (Wire Twister). Principal changes in this edition of the Standard are consolidation of Types and Classes and updated references.

The format of this standard is in accordance with *The ASME Codes & Standards Writing Guide 2000*. Requests for interpretations of the technical requirements of this Standard should be expressed in writing to the Secretary, B107 Committee, at the address below.

Suggestions for the improvement of this Standard are welcome. They should be addressed to the Secretary, ASME B107 Committee, Three Park Avenue, New York, NY 10016-5990.

The requirements of this Standard become effective at the time of publication.

This revision was approved as an American National Standard on May 1, 2003.

# ASME STANDARDS COMMITTEE B107

## Hand Tools and Accessories

(The following is the roster of the Committee at the time of approval of this Standard.)

### OFFICERS

G. E. Olson, *Chair*  
W. T. Pagac, *Vice Chair*  
J. R. Bird, *Secretary*

### COMMITTEE PERSONNEL

J. R. Bird, The American Society of Mechanical Engineers  
J. Davidson, Sears Roebuck and Co.  
P. A. Desmarais, Danaher Tool Group  
J. S. Foote, Trade Association Management, Inc.  
A. Herskowitz, Consultant  
D. S. McKittrick, Western Forge  
G. E. Olson, Gene Olson Engineering Consultant, Ltd.  
W. T. Pagac, Snap-on, Inc.  
D. M. Eggert, *Alternate*, Snap-on, Inc.  
J. M. Star, General Services Administration  
I. F. Harding, *Alternate*, General Services Administration  
R. B. Wright, Wright Tool Co.  
W. C. Snyder, *Alternate*, Wright Tool Co.

### SUBCOMMITTEE 5 — PLIERS AND SNIPS

D. S. McKittrick, *Chair*, Western Forge  
J. Davidson, Sears Roebuck and Co.  
J. S. Foote, Trade Association Management, Inc.  
J. M. Star, General Services Administration

## CORRESPONDENCE WITH THE B107 COMMITTEE

**General.** ASME standards are developed and maintained with the intent to represent the consensus of concerned interests. As such, users of this Standard may interact with the Committee by requesting interpretations, proposing revisions, and attending Committee meetings. Correspondence should be addressed to:

Secretary, B107 Standards Committee  
The American Society of Mechanical Engineers  
Three Park Avenue  
New York, NY 10016-5990

**Proposing Revisions.** Revisions are made periodically to the Standard to incorporate changes that appear necessary or desirable, as demonstrated by the experience gained from the application of the Standard. Approved revisions will be published periodically.

The Committee welcomes proposals for revisions to this Standard. Such proposals should be as specific as possible, citing the paragraph number(s), the proposed wording, and a detailed description of the reasons for the proposal, including any pertinent documentation.

**Interpretations.** Upon request, the B107 Committee will render an interpretation of any requirement of the Standard. Interpretations can only be rendered in response to a written request sent to the Secretary of the B107 Standards Committee.

The request for interpretation should be clear and unambiguous. It is further recommended that the inquirer submit his/her request in the following format:

Subject:	Cite the applicable paragraph number(s) and the topic of the inquiry.
Edition:	Cite the applicable edition of the Standard for which the interpretation is being requested.
Question:	Phrase the question as a request for an interpretation of a specific requirement suitable for general understanding and use, not as a request for an approval of a proprietary design or situation. The inquirer may also include any plans or drawings, which are necessary to explain the question; however, they should not contain proprietary names or information.

Requests that are not in this format will be rewritten in this format by the Committee prior to being answered, which may inadvertently change the intent of the original request.

ASME procedures provide for reconsideration of any interpretation when or if additional information that might affect an interpretation is available. Further, persons aggrieved by an interpretation may appeal to the cognizant ASME Committee or Subcommittee. ASME does not "approve," "certify," "rate," or "endorse" any item, construction, proprietary device, or activity.

**Attending Committee Meetings.** The B107 Standards Committee regularly holds meetings, which are open to the public. Persons wishing to attend any meeting should contact the Secretary of the B107 Standards Committee.

# PLIERS: WIRE TWISTER

## 1 SCOPE

This Standard is intended to cover the general dimensional and functional characteristics for wire twister pliers, which are used primarily for twisting safety wires (lock wire) on critical equipment on aircraft, automotive equipment, and for other similar applications.

Inclusion of dimensional data in this Standard is not intended to imply that all products described herein are stock production sizes. Consumers are requested to consult with manufacturers concerning lists of stock production sizes.

This Standard may be used as a guide by state authorities or other regulatory bodies in the formulation of laws or regulations. It is also intended for voluntary use by establishments that use or manufacture the tools covered.

## 2 CLASSIFICATION

### Type I: Right-hand twist

*Class 1:* With automatic (spring-loaded) twist rod return mechanism

Style A: Serrated wire clamping jaw surface

Style B: Smooth wire clamping jaw surfaces (no serrations)

*Class 2:* With hand push twist rod return

Style A: Serrated wire clamping jaw surface

Style B: Smooth wire clamping jaw surfaces (no serrations)

### Type II: Left-hand twist

*Class 1:* With automatic (spring-loaded) twist rod return mechanism

Style A: Serrated wire clamping jaw surface

Style B: Smooth wire clamping jaw surfaces (no serrations)

*Class 2:* With hand push twist rod return

Style A: Serrated wire clamping jaw surface

Style B: Smooth wire clamping jaw surfaces (no serrations)

### Type III: Reversible

*Class 1:* With automatic (spring-loaded) twist rod return mechanism

Style A: Serrated wire clamping jaw surface

Style B: Smooth wire clamping jaw surfaces (no serrations)

*Class 2:* With hand push twist rod return

Style A: Serrated wire clamping jaw surface

Style B: Smooth wire clamping jaw surfaces (no serrations)

## 3 NORMATIVE REFERENCES

The following documents form a part of this Standard to the extent specified herein. At the time of publication, the editions indicated were valid. All standards are subject to revision, and parties to agreements based on this American National Standard are encouraged to investigate the possibility of applying the most recent editions of the documents indicated below.

ASME B107.25M-1996 Pliers — Performance Test Methods

Publisher: The American Society of Mechanical Engineers (ASME International), Three Park Avenue, New York, NY 10016-5990; Order Department: 22 Law Drive, Box 2300, Fairfield, NJ 07007-2300

ASTM A313-98 Standard Specification for Stainless Steel Spring Wire

Publisher: The American Society for Testing and Materials (ASTM), 100 Barr Harbor Drive, West Conshohocken, PA 19428-2959

Guide to Hand Tools — Selection, Safety Tips, Proper Use and Care

Publisher: The Hand Tools Institute (HTI), 25 North Broadway, Tarrytown, NY 10591

## 4 DEFINITIONS

Definitions of terms used within this Standard may be found in ASME B107.25M.

## 5 REQUIREMENTS

The illustrations shown herein are descriptive and nonrestrictive, and are not intended to preclude the manufacture of wire twisters that are otherwise in accordance with this Standard.

### 5.1 Design

Wire twister pliers shall conform to Table 1 or 1M for the size specified, shall be similar to those shown in Fig. 5, and shall meet the dimensional requirements of Fig. 1, 2, 3, or 4. They shall be capable of passing all tests outlined in para. 6.

**Table 1** Dimensions of Pliers, Wire Twister, With Side Cutter (See Fig. 5)

Nominal Size	A	B	C
6	6.75 ± 0.50	1.38 ± 0.25	8.50 ± 0.50
9	8.88 ± 0.50	1.50 ± 0.25	10.25 ± 0.25
12	10.18 ± 0.50	1.75 ± 0.25	11.38 ± 0.50

General Note: Dimensions are in inches.

**Table 1M** Dimensions of Pliers, Wire Twister, With Side Cutter (See Fig. 5)

Nominal Size	A	B	C
152	171 ± 13	35 ± 6	216 ± 13
229	225 ± 13	38 ± 6	260 ± 6
305	259 ± 13	44 ± 6	289 ± 13

General Note: Dimensions are in millimeters.

Wire twister pliers shall incorporate a device, which, when actuated, will cause the pliers to rotate about its longitudinal axis. The halves of the pliers shall be permanently joined with a through fastener that shall act as the pivot or fulcrum point of the pliers. A locking device, when engaged, shall hold the handles in a closed position in such a manner as to cause the jaws to firmly and securely grip and hold strands of lock wire.

A wire clearance opening shall be provided between the two jaws and located between the gripping and cutting areas of the jaws. This opening shall be of a size and design which will permit the user to swiftly and easily deflect double strands of wire out of the sides of the jaws and away from the cutting edges when performing continuous (multiple) lock wiring operations. The nose design shall be as shown in Figs. 1 through 4 and blend with the radius of the sides of the pliers in accordance with good commercial practice. The maximum permissible opening at the top of the jaws, when closed, shall be as shown in Figs. 1 and 2.

## 5.2 Material

The materials used in the manufacture of the pliers shall be such as to produce pliers conforming to the requirements specified herein.

## 5.3 Finish

Surfaces shall have a rust preventive treatment and be essentially free from pits, nodules, burrs, cracks, and other conditions that would adversely affect the performance or safety of the tool. When provided, coatings shall be adherent, smooth, continuous, and free from any conditions that would interfere with their protective value, safety, and function.

## 5.4 Marking

Pliers shall be marked in a plain and permanent manner with the manufacturer's name or with a trademark of such known character that the source of manufacture and country of origin shall be readily determined. Marking shall be as permanent as the normal life expectancy of the pliers to which it is applied (providing the marked surface has not been subjected to a fretting or abrading action) and be capable of withstanding the cleaning procedures normally experienced during its intended use.

## 5.5 Handles

Handles shall have a hardness of 36 HRC to 50 HRC, shall be shaped to provide a comfortable handgrip, and shall be free from rough edges and sharp corners.

## 5.6 Jaws

**5.6.1 Hardness.** Jaws shall have a hardness of 36 HRC to 50 HRC. The gripping portion of the jaws and wire cutter shall be heat treated to a hardness of 56 HRC to 64 HRC. Jaw surfaces and edges shall not damage the wire being twisted.

**5.6.2 Cushion Grip Throat.** Cushion grip throat, when provided, shall grip and retain cut wire end. The cushion grip throat shall be nonmetallic and capable of withstanding normal use without deteriorating or rubbing off and shall pass the solvent resistance test in para. 6.4. Cushion grip throat shall remain permanently attached under normal use.

## 5.7 Joint Fastener

The fastener shall have a hardness of 25 HRC to 50 HRC.

## 5.8 Spiral Mechanism

The spiral mechanism shall be capable of producing a close, uniform twist in safety wire without binding of or damage to the mechanism. This mechanism shall be mounted between the handles of the pliers and shall be permanently affixed to one handle in such a position that the longitudinal axis of the mechanism shall correspond to the longitudinal axis of the pliers. The mechanism, when actuated, shall cause pliers to rotate about its longitudinal axis in its intended direction(s). Each full actuation of the mechanism shall cause the pliers to make the following minimum number of complete rotations:

(a) for 6 in. (152 mm) size, 2½ rotations (with automatic return, 2 rotations)

(b) for 9 in. (229 mm) size, 3 rotations (with automatic return, 2½ rotations)

(c) for 12 in. (305 mm) size, 4 rotations (with automatic return, 3½ rotations) (Type III Reversible, 3 rotations)

The design of the mechanism shall permit a comfortable, adequate grip by the operator.



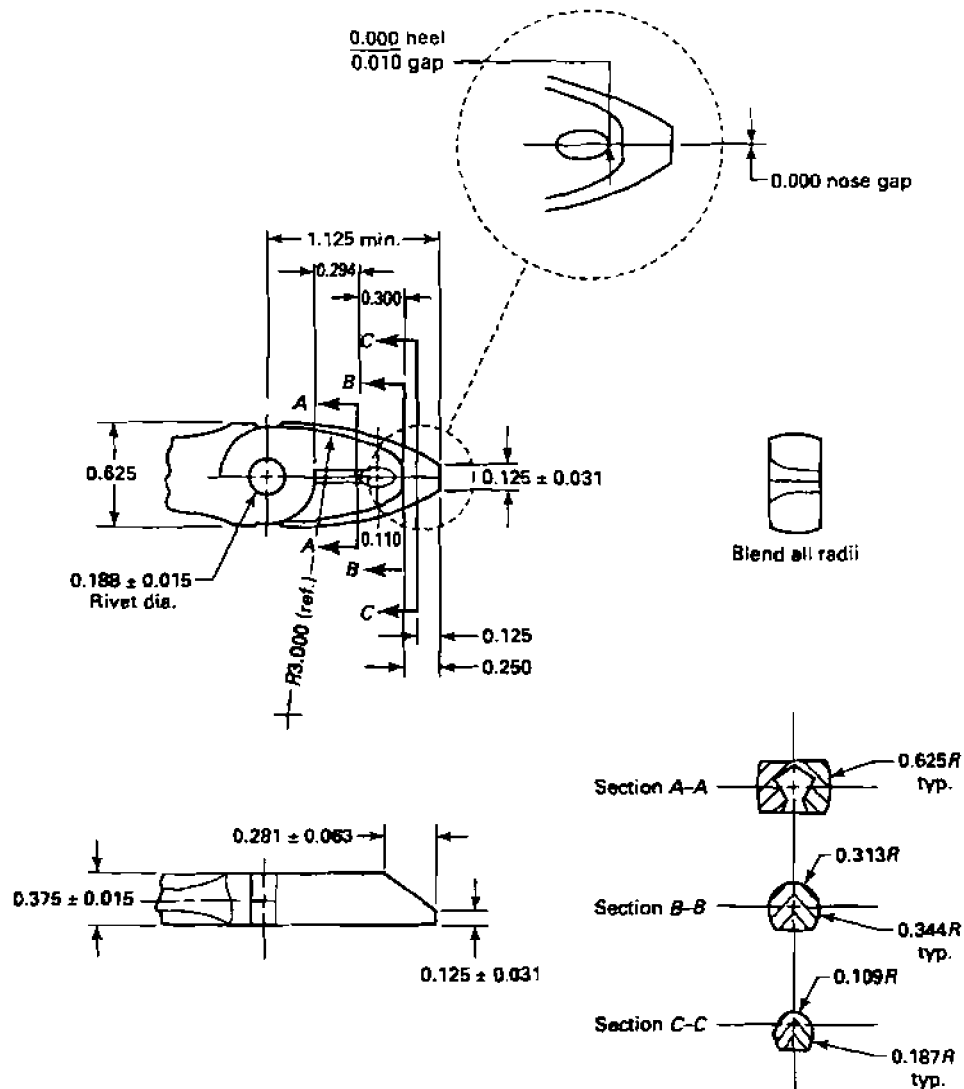

GENERAL NOTE: Gap of nose must not exceed gap at heel of serration. Gap should be uniform in nature around serrated jaw edges. Measurements to be taken with jaws in closed position.

Fig. 1 Nose Design, Pliers, Wire Twister, 6 in.

5.9 Locking Device

The locking device shall be so designed that when the pliers' jaws are closed, the handles must be further compressed in order to engage the lock. Release of the locking device shall be accomplished automatically when the handles are compressed. The locking device shall not interfere with the user's hands when performing lock wiring operations.

6 TESTS

**SAFETY WARNING:** Many tests required herein are inherently hazardous and adequate safeguards for personnel and property shall be employed in conducting these tests.

6.1 Test Equipment

The equipment required for performing the wire twisting tests shall consist of a coupler securely attached to a 35 lb (16 kg) ± 0.5 lb (0.2 kg) weight so that a 0.051

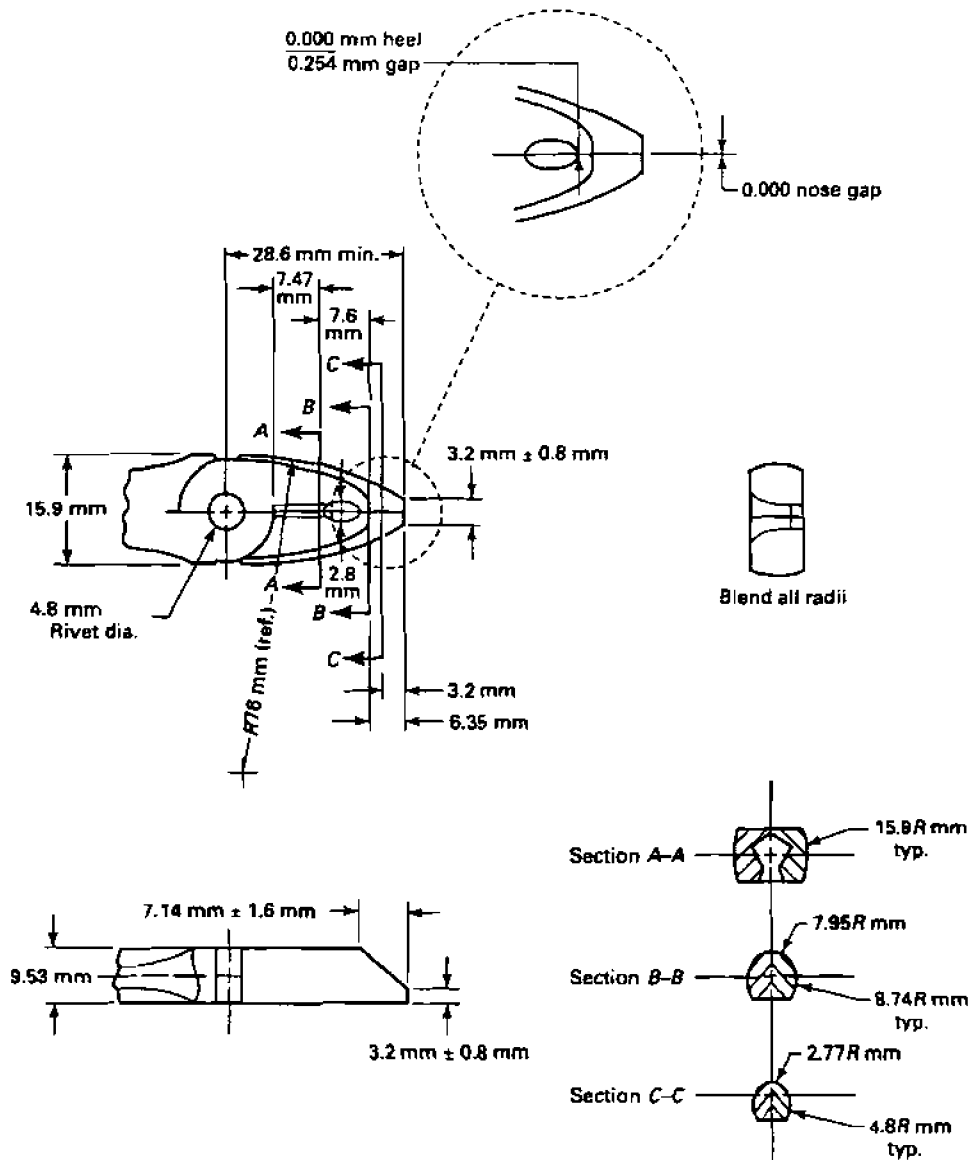

GENERAL NOTE: Gap of nose must not exceed gap at heel of serration. Gap should be uniform in nature around serrated jaw edges. Measurements to be taken with jaws in closed position.

Fig. 2 Nose Design, Pliers, Wire Twister, 152 mm

in. (1.30 mm) diameter stainless steel test wire may be looped through the coupler. The weight shall not rotate on its vertical axis during the wire twisting test.

6.2 Jaw Integrity Test

The wire shall be attached to the weight by passing one end through the coupler, and then gripping both free ends of the wire with the jaws of the pliers. The

ends of the wire shall be inserted side-by-side between the pliers jaws to a depth of approximately 0.5 in. (13 mm), and shall provide from 7.5 in. (191 mm) to 7.88 in. (200 mm) of free wire extending beyond the coupler for twisting. The jaws shall be locked in the gripping position. The wire shall then be twisted by actuating the spiral mechanism a sufficient number of times to produce a minimum of ten uniform tight twists of 360

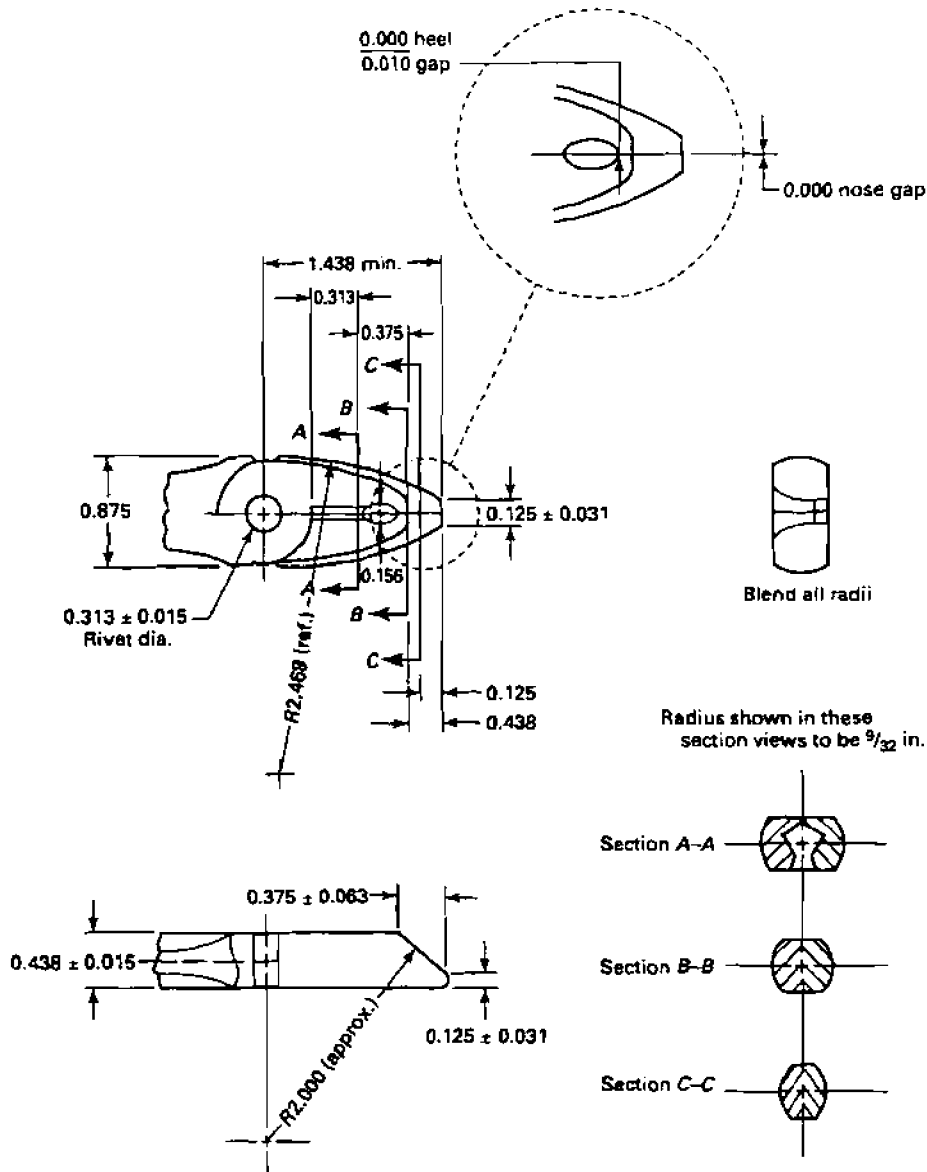

GENERAL NOTE: Gap of nose must not exceed gap at heel of serration. Gap should be uniform in nature around serrated jaw edges. Measurements to be taken with jaws in closed position.

Fig. 3 Nose Design, Pliers, Wire Twister, 9 in. and 12 in.

deg each in the wire. Without releasing the grip on the wire, the pliers shall then be made to lift the weight by means of the twisted wire and shall hold the suspended weight for a minimum of 15 sec.

6.3 Cut Tests

6.3.1 Wire Cut Test. Pliers shall cut, at the joint end of the cutting edge, the wire sizes (using the load limits) shown in Table 2 or 2M. Wire shall conform to ASTM

A 313. Three cuts of double twisted wire (one cut per size) and three cuts of single strand wire (0.020) shall be made. After completing the cuts, pliers shall lift a weight of 35 lb (16 kg) suspended on a 0.020 wire.

6.3.2 Paper Cut Test. Test per ASME B107.25M.

6.4 Solvent Resistance Test

Nonmetallic components shall be tested per para. 5.5.1 of ASME B107.25M.

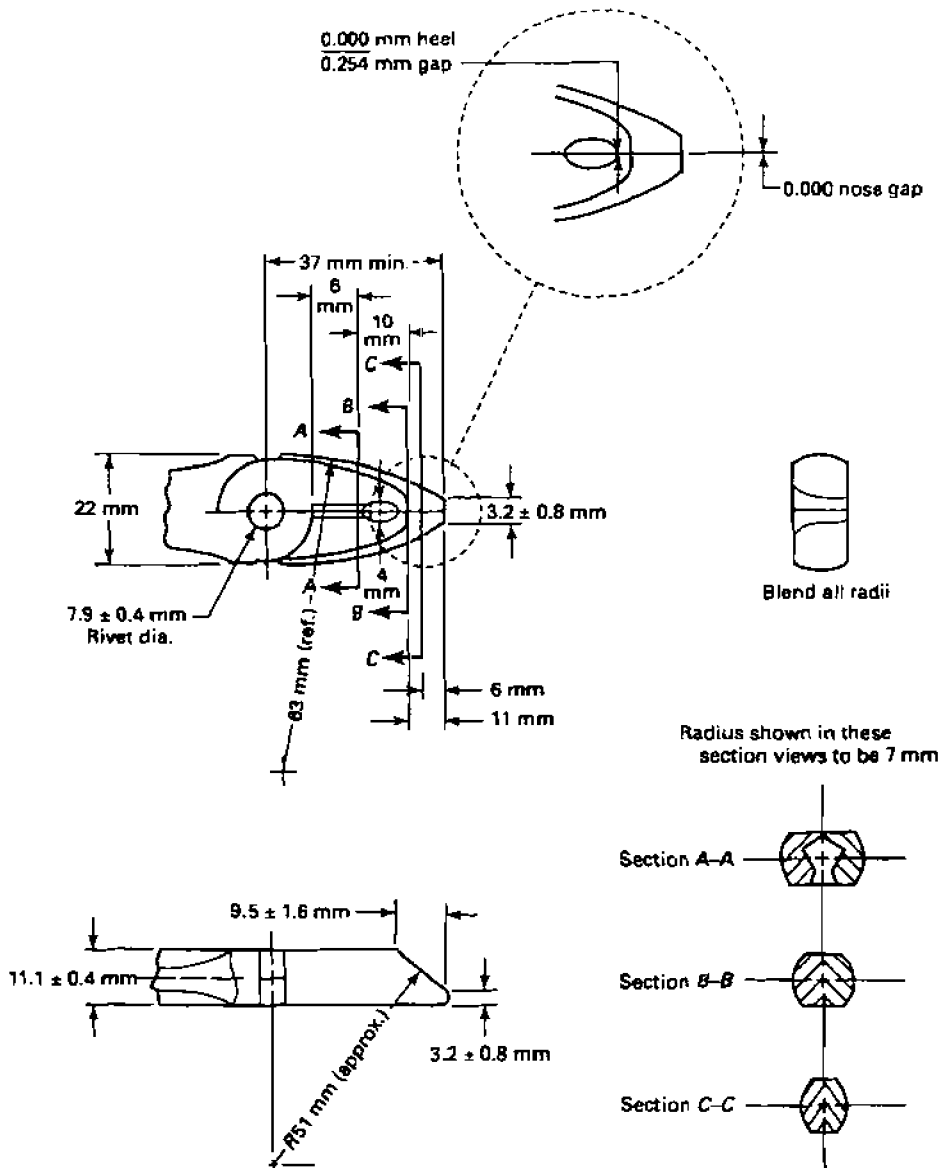

GENERAL NOTE: Gap of nose must not exceed gap at heel of serration. Gap should be uniform in nature around serrated jaw edges. Measurements to be taken with jaws in closed position.

Fig. 4 Nose Design, Pliers, Wire Twister, 229 mm and 305 mm

**6.5 Hardness Test**

Hardnesses specified herein shall be tested per ASME B107.25M. (See para. 5.3.)

**6.6 Joint Integrity Test**

Pliers shall be tested per para. 5.4.1 of ASME B107.25M using a minimum of 1.50 lbf (6.7 N). Maximum allowable

play shall be 0.01 in. per in. (0.025 mm per 25.4 mm).

**6.7 Pull Knob Security Test**

With the spiral rod in the retracted position, a 100 lbf (448 N) load shall be attached to the pull knob. A force shall then be applied to the pliers, which will simultaneously extend the spiral rod and lift the 100 lbf (448 N) load for one minute. After completion of the test, the

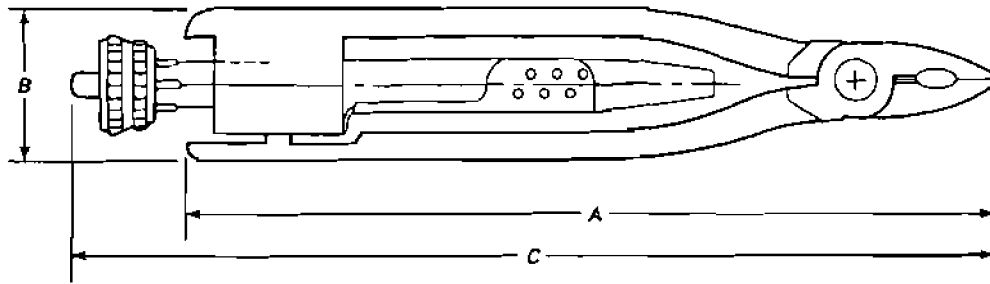

Fig. 5 Pliers Wire Twister, With Side Cutter in Locked Position

knob shall have remained in place with no visible deformation. In addition, the spiral rod shall function as it did prior to the test.

**7 SAFETY REQUIREMENTS AND LIMITATIONS OF USE**

Instructors and employers shall stress proper use and safety in the use of pliers, information about which can be found in the HTI publication, *Guide to Hand Tools — Selection Safety Tips, Proper Use and Care.*

**8 DESIGNATIONS**

Pliers shall be designated by the following data in the sequence shown:

- (a) type
- (b) class
- (c) style
- (d) nominal size
- (e) return mechanism

**Table 2 Wire Cut Test Parameters**

Nominal Size	Double Cut Wire Sizes, in.	Load Application Distance From Handle End, in.	Maximum Load to Cut Wire, lbf
6	0.041, 0.032, 0.020	1	48
9	0.051, 0.041, 0.020	2	55
12	0.051, 0.041, 0.020	2	47

General Note: Dimensions are in inches.

**Table 2M Wire Cut Test Parameters**

Nominal Size	Double Cut Wire Sizes, mm	Load Application Distance from Handle End, mm	Maximum Load to Cut Wire, N
152	1.04, 0.81, 0.51	25	213
229	1.30, 1.04, 0.51	51	244
305	1.30, 1.04, 0.51	51	209

General Note: Dimensions are in millimeters.

## AMERICAN NATIONAL STANDARDS FOR HAND TOOLS

Socket Wrenches, Hand (Inch Series) .....	B107.1-2002
Socket Wrenches, Extensions, Adaptors, and Universal Joints, Power Drive (Impact) (Inch Series) .....	B107.2-2002
Driving and Spindle Ends for Portable Hand, Impact, Air, and Electric Tools (Percussion Tools Excluded) .....	B107.4M-1995
Socket Wrenches, Hand (Metric Series) .....	B107.5M-2002
Adjustable Wrenches .....	B107.8-2003
Handles and Attachments for Hand Socket Wrenches — Inch and Metric Series .....	B107.10M-1996
Pliers: Diagonal Cutting and End Cutting .....	B107.11-2002
Nut Drivers (Spin Type, Screwdriver Grip) (Inch Series) .....	B107.12-1997
Pliers: Long Nose, Long Reach .....	B107.13-2003
Hand Torque Tools .....	B107.14M-1994
Flat Tip Screwdrivers .....	B107.15-2002
Shears (Metal Cutting, Hand) .....	B107.16M-1998
Gages, Wrench Openings, Reference .....	B107.17M-1997
Pliers: Wire Twister .....	B107.18-2003
Pliers, Retaining Ring .....	B107.19-1993(R1998)
Pliers (Lineman's, Iron Worker's, Gas, Glass, Fence, and Battery) .....	B107.20M-1998
Wrench, Crowfoot Attachments .....	B107.21-1998
Electronic Cutters .....	B107.22M-1998
Pliers, Multiple Position, Adjustable .....	B107.23M-1997
Locking Pliers .....	B107.24-2002
Pliers: Performance Test Methods .....	B107.25-2002
Pliers: Multiple Position, Electrical Connector .....	B107.27-2003
Electronic Torque Instruments .....	B107.28M-1997
Electronic Tester, Hand Torque Tools .....	B107.29M-1998
Cross Tip Screwdrivers .....	B107.30-2002
Screwdrivers, Cross Tip Gaging .....	B107.31M-1997
Socket Wrenches, Impact (Metric Series) .....	B107.33M-2002
Socket Wrenches for Spark Plugs .....	B107.34-2003
Nut Drivers (Spin Type, Screwdriver Grip) (Metric Series) .....	B107.35M-1997
Pliers: Locking, Clamp, and Tubing Pinch-Off .....	B107.36-2002
Pliers: Wire Cutters/Strippers .....	B107.37-2003
Electronic Pliers .....	B107.38M-1998
Nail Hammers — Safety Requirements .....	B107.41M-1997
Hatchets: Safety Requirements .....	B107.42M-1997
Wood-Splitting Wedges .....	B107.43-2002
Glaziers' Chisels and Wood Chisels .....	B107.44-2002
Ripping Chisels and Flooring/Electricians' Chisels .....	B107.45-2002
Stud, Screw, and Pipe Extractors: Safety Requirements .....	B107.46M-1998
Metal Chisels: Safety Requirements .....	B107.47M-1998
Metal Punches and Drift Pins: Safety Requirements .....	B107.48M-1998
Nail Sets: Safety Requirements .....	B107.49M-1998
Brick Chisels and Brick Sets: Safety Requirements .....	B107.50M-1998
Star Drills: Safety Requirements .....	B107.51-2001
Nail-Puller Bars: Safety Requirements .....	B107.52M-1998
Ball Peen Hammers: Safety Requirements .....	B107.53M-1998
Heavy Striking Tools: Safety Requirements .....	B107.54-2001
Axes: Safety Requirements .....	B107.55M-2002
Body Repair Hammers and Dolly Blocks: Safety Requirements .....	B107.56-1999
Bricklayers' Hammers and Prospecting Picks: Safety Requirements .....	B107.57-2001
Riveting, Scaling, and Tinner's Setting Hammers: Safety Requirements .....	B107.58M-1998
Slugging and Striking Wrenches .....	B107.59-2002
Wrenches .....	B107.100-2002

*The ASME Publications Catalog shows a complete list of all the Standards published by the Society. For a complimentary catalog, or the latest information about our publications, call 1-800-THE-ASME (1-800-843-2763).*

---

## ASME Services

ASME is committed to developing and delivering technical information. At ASME's Information Central, we make every effort to answer your questions and expedite your orders. Our representatives are ready to assist you in the following areas:

ASME Press  
Codes & Standards  
Credit Card Orders  
IMEchE Publications  
Meetings & Conferences  
Member Dues Status

Member Services & Benefits  
Other ASME Programs  
Payment Inquiries  
Professional Development  
Short Courses  
Publications

Public Information  
Self-Study Courses  
Shipping Information  
Subscriptions/Journals/Magazines  
Symposia Volumes  
Technical Papers

### How can you reach us? It's easier than ever!

There are four options for making inquiries\* or placing orders. Simply mail, phone, fax, or E-mail us and an Information Central representative will handle your request.

**Mail**  
ASME  
22 Law Drive, Box 2900  
Fairfield, New Jersey  
07007-2900

**Call Toll Free**  
**US & Canada:** 800-THE-ASME  
(800-843-2763)  
**Mexico:** 95-800-THE-ASME  
(95-800-843-2763)  
**Universal:** 973-882-1167

**Fax—24 hours**  
973-882-1717  
973-882-5155

**E-Mail—24 hours**  
[infocentral@asme.org](mailto:infocentral@asme.org)

\* Information Central staff are not permitted to answer inquiries about the technical content of this code or standard. Information as to whether or not technical inquiries are issued to this code or standard is shown on the copyright page. All technical inquiries must be submitted in writing to the staff secretary. Additional procedures for inquiries may be listed within.