

DIN ISO 5745

DIN

ICS 25.140.30

Supersedes
DIN ISO 5745:1994-09

**Pliers and nippers –
Pliers for gripping and manipulating –
Dimensions and test values (ISO 5745:2004)
English version of DIN ISO 5745:2006-09**

Greif- und Schneidzangen –
Greifzangen –
Maße und Prüfwerte (ISO 5745:2004)
Englische Fassung DIN ISO 5745:2006-09

Document comprises 13 pages

Contents

	Page
National foreword	2
National Annex NA (informative) Bibliography	3
1 Scope	4
2 Normative references	4
3 Dimensions and test values	4
3.1 Round nose pliers for gripping and manipulating	4
3.2 Flat nose pliers for gripping and manipulating	6
3.3 Snipe nose pliers for gripping and manipulating	7
3.4 Snipe nose pliers with side cutter for medium hard wire	9
3.5 Flat nose pliers with side cutter for medium hard wire	10
4 Designation	11
5 Marking	12
Bibliography	13

National foreword

This standard has been prepared by Technical Committee ISO/TC 29 “Small tools”, Subcommittee SC 10 “Assembly tools for screws and nuts, pliers and nippers”.

The responsible German body involved in its preparation was the *Normenausschuss Werkzeuge und Spannzeuge* (Tools and Clamping Devices Standards Committee), Technical Committee NA 121-09-01 AA *Zangen*.

The DIN Standards corresponding to the International Standards referred to in clause 2 of the ISO Standard are as follows:

ISO 5743 DIN ISO 5743
 ISO 5744 DIN ISO 5744

Amendments

This standard differs from DIN ISO 5745:1994-09 as follows:

- a) The content of the standard has been updated.
- b) The scope has been extended to include flat nose pliers with side cutter.
- c) A new clause 4 “Designation” has been included.
- d) A new clause 5 “Marking” has been included.
- e) The standard has been editorially revised.

Previous editions

DIN 5236: 1967-11
DIN 5248: 1936-04, 1941-04, 1967-11
DIN 5249: 1936-04, 1941-04, 1967-11
DIN 5257: 1933-10, 1941-04, 1967-11
DIN 5258: 1933-10, 1941-04, 1967-11
DIN ISO 5745: 1994-09

National Annex NA
(informative)

Bibliography

DIN ISO 5743, *Pliers and nippers — General technical requirements*

DIN ISO 5744:2006, *Pliers and nippers — Methods of test*

Pliers and nippers — Pliers for gripping and manipulating — Dimensions and test values

1 Scope

This International Standard specifies the principal dimensions of pliers for gripping and manipulating and the test values for the pliers in order to verify their aptitude to function in conformity with ISO 5744. General technical requirements are given in ISO 5743.

The pliers for gripping and manipulating illustrated in this International Standard are examples only and are not intended to affect the manufacturer's design.

2 Normative references

The following referenced documents are indispensable for the application of this document. For dated references, only the edition cited applies. For undated references, the latest edition of the referenced document (including any amendments) applies.

ISO 5743, *Pliers and nippers — General technical requirements*

ISO 5744:2004, *Pliers and nippers — Methods of test*

3 Dimensions and test values

3.1 Round nose pliers for gripping and manipulating

The principal dimensions for round nose pliers for gripping and manipulating are shown in Figure 1 and given in Table 1.

Round nose pliers shall be tested in accordance with ISO 5744.

After the load test, the permanent set s shall not exceed the value given in Table 2. If distance l_1 is not suitable for the load test, the formula given in ISO 5744:2004, 4.2 shall be used.

Dimensions in millimetres

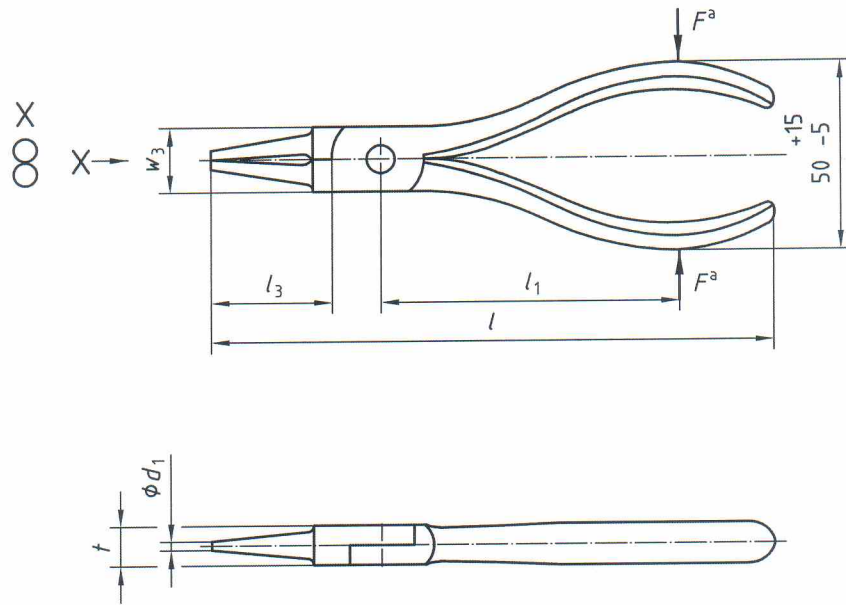

a F = Load applied in load test.

Figure 1 — Round nose pliers for gripping and manipulating

Table 1 — Round nose pliers for gripping and manipulating, principal dimensions

Dimensions in millimetres

Length of nose	l	l_3	d_1 max.	w_3 max.	t max.
Short nose	$125 \pm 6,3$	$25 \begin{smallmatrix} 0 \\ -5 \end{smallmatrix}$	2	16	9
	140 ± 8	$32 \begin{smallmatrix} 0 \\ -6,3 \end{smallmatrix}$	2,8	18	10
	160 ± 8	$40 \begin{smallmatrix} 0 \\ -8 \end{smallmatrix}$	3,2	20	11
Long nose	140 ± 7	40 ± 4	2,8	17	9
	160 ± 8	50 ± 5	3,2	19	10
	180 ± 9	$63 \pm 6,3$	3,6	20	11

Table 2 — Round nose pliers for gripping and manipulating, torsion and load test values

Length of nose	Nominal length l mm	l_1 mm	Torsion test		Load test	
			Torque T N · m	Maximum twist α_{\max}	Load F N	Maximum permanent set s_{\max}^a mm
Short nose	125	63	0,5	20°	630	1
	140	71	1,0		710	
	160	80	1,25		800	
Long nose	140	63	0,25	25°	630	
	160	71	0,5		710	
	180	80	1,0		800	

^a $s = w_1 - w_2$ (see ISO 5744).

3.2 Flat nose pliers for gripping and manipulating

The principal dimensions of flat nose pliers for gripping and manipulating are shown in Figure 2 and given in Table 3.

Flat nose pliers shall be tested in accordance with ISO 5744.

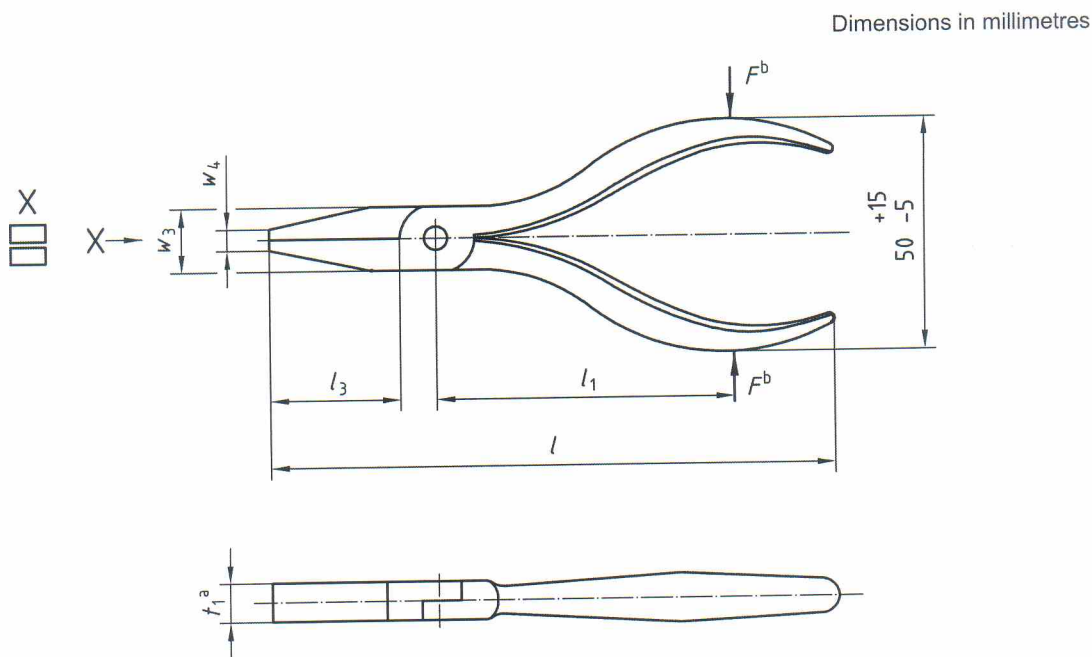

- a The head may be tapered over the length l_3 .
- b F = Load applied in load test.

Figure 2 — Flat nose pliers for gripping and manipulating

**Table 3 — Flat nose pliers for gripping and manipulating,
principal dimensions**

Dimensions in millimetres

Length of nose	l	l_3	w_3 max.	w_4 max.	t_1 max.
Short nose	125 ± 6	$25 \begin{smallmatrix} 0 \\ -5 \end{smallmatrix}$	16	3,2	9
	140 ± 7	$32 \begin{smallmatrix} 0 \\ -6,3 \end{smallmatrix}$	18	4	10
	160 ± 8	$40 \begin{smallmatrix} 0 \\ -8 \end{smallmatrix}$	20	5	11
Long nose	140 ± 7	40 ± 4	16	3,2	9
	160 ± 8	50 ± 5	18	4	10
	180 ± 9	$63 \pm 6,3$	20	5	11

After the load test, the permanent set s shall not exceed the value given in Table 4. If distance l_1 is not suitable for the load test, the formula given in ISO 5744:2004, 4.2 shall be used.

**Table 4 — Flat nose pliers for gripping and manipulating,
torsion and load test values**

Length of nose	Nominal length l mm	l_1 mm	Torsion test		Load test	
			Torque T N·m	Maximum twist α_{\max}	Load F N	Maximum permanent set s_{\max}^a mm
Short nose	125	63	4	20°	630	1
	140	71	5	20°	710	1
	160	80	6	20°	800	1
Long nose	140	63	—	—	630	1
	160	71	—	—	710	1
	180	80	—	—	800	1

^a $s = w_1 - w_2$ (see ISO 5744).

3.3 Snipe nose pliers for gripping and manipulating

The principal dimensions for snipe nose pliers for gripping and manipulating are shown in Figure 3 and given in Table 5.

Snipe nose pliers shall be tested in accordance with ISO 5744.

After the load test, the permanent set s shall not exceed the value given in Table 6. If distance l_1 is not suitable for the load test, the formula given in ISO 5744:2004, 4.2 shall be used.

Dimensions in millimetres

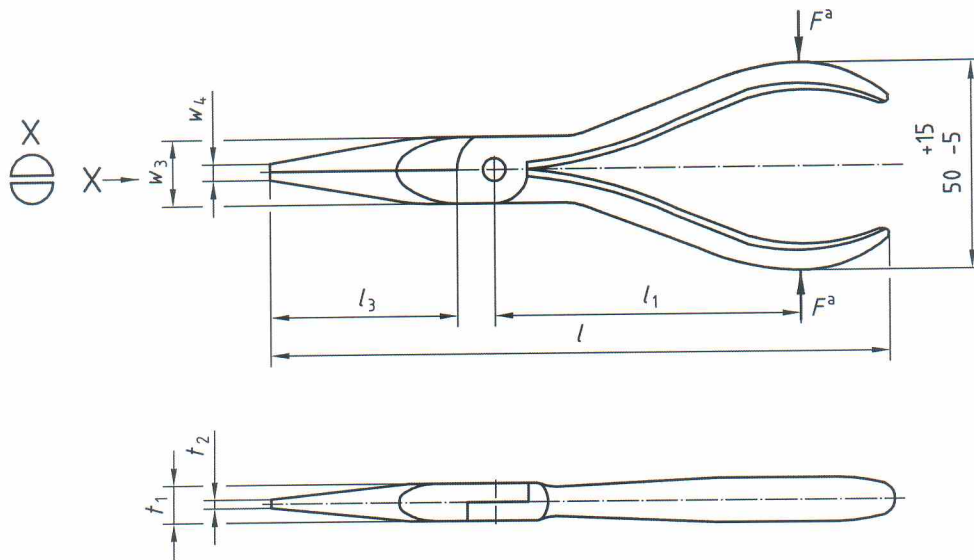

a F = Load applied in load test.

Figure 3 — Snipe nose pliers for gripping and manipulating

Table 5 — Snipe nose pliers for gripping and manipulating, principal dimensions

Dimensions in millimetres

l	l_3	w_3 max.	w_4 max.	t_1 max.	t_2 max.
140 ± 7	40 ± 5	16	2,5	9	2
160 ± 8	53 ± 6,3	19	3,2	10	2,5
180 ± 10	60 ± 8	20	5	11	3
200 ± 10	80 ± 10	22	5	12	4
280 ± 14	80 ± 14	22	5	12	4

Table 6 — Snipe nose pliers for gripping and manipulating, load test values

Nominal length		Load test	
		Load	Maximum permanent set
l mm	l_1 mm	F N	s_{max}^a mm
140	63	630	1
160	71	710	1
180	80	800	1
200	90	900	1
280	140	630	1

^a $s = w_1 - w_2$ (see ISO 5744).

3.4 Snipe nose pliers with side cutter for medium hard wire

The principal dimensions for snipe nose pliers for gripping and manipulating are shown in Figure 4 and given in Table 7.

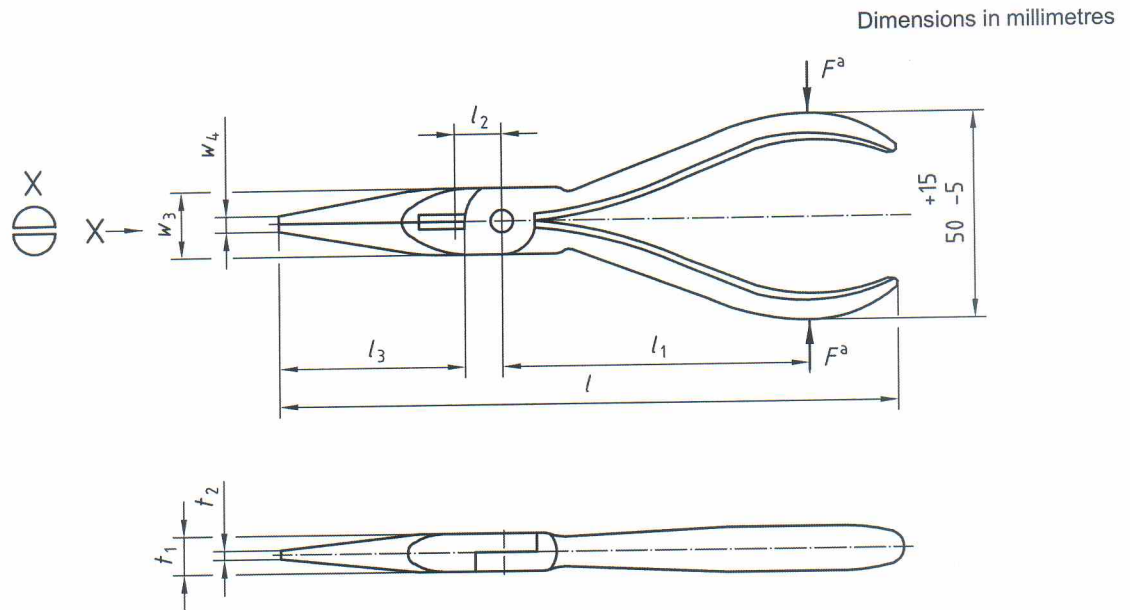

a F = Load applied in load test or F_1 force applied in cutting test.

Figure 4 — Snipe nose pliers with side cutter for medium hard wire

Table 7 — Snipe nose pliers with side cutter for medium hard wire, principal dimensions

Dimensions in millimetres

l	l_3	w_3 max.	w_4 max.	t_1 max.	t_2 max.
140 ± 7	40 ± 5	16	2,5	9	2
160 ± 8	$53 \pm 6,3$	19	3,2	10	2,5
180 ± 10	60 ± 8	20	5	11	3
200 ± 10	80 ± 10	22	5	12	4

Snipe nose pliers shall be tested in accordance with ISO 5744.

After the load test, the permanent set s shall not exceed the value given in Table 8. If distance l_1 is not suitable for the load test, the formula given in ISO 5744:2004, 4.2 shall be used.

The cutting force, F_1 , and the diameter, d , of the test wire shall not exceed the values given in Table 8.

Pliers having a lever ratio differing from the values given in Table 8 shall be checked for compliance using the formula given in ISO 5744:2004, 5.3.2.

Table 8 — Snipe nose pliers with side cutter for medium hard wire, dimensions for load and force application, test values

Nominal length l mm	l_1 mm	l_2 mm	Cutting test		Load test	
			Diameter of medium hard test wire d^a mm	Maximum cutting force $F_{1, \max}$ N	Load F N	Maximum permanent set s_{\max}^b mm
140	63	12,5	1,6	570	630	1
160	71	14	1,6	570	710	1
180	80	16	1,6	570	800	1
200	90	18	1,6	570	900	1

^a Data for medium hard test wire are given in ISO 5744.
^b $s = w_1 - w_2$ (see ISO 5744).

3.5 Flat nose pliers with side cutter for medium hard wire

The principal dimensions for flat nose pliers for gripping and manipulating are shown in Figure 5 and given in Table 9.

Flat nose pliers shall be tested in accordance with ISO 5744.

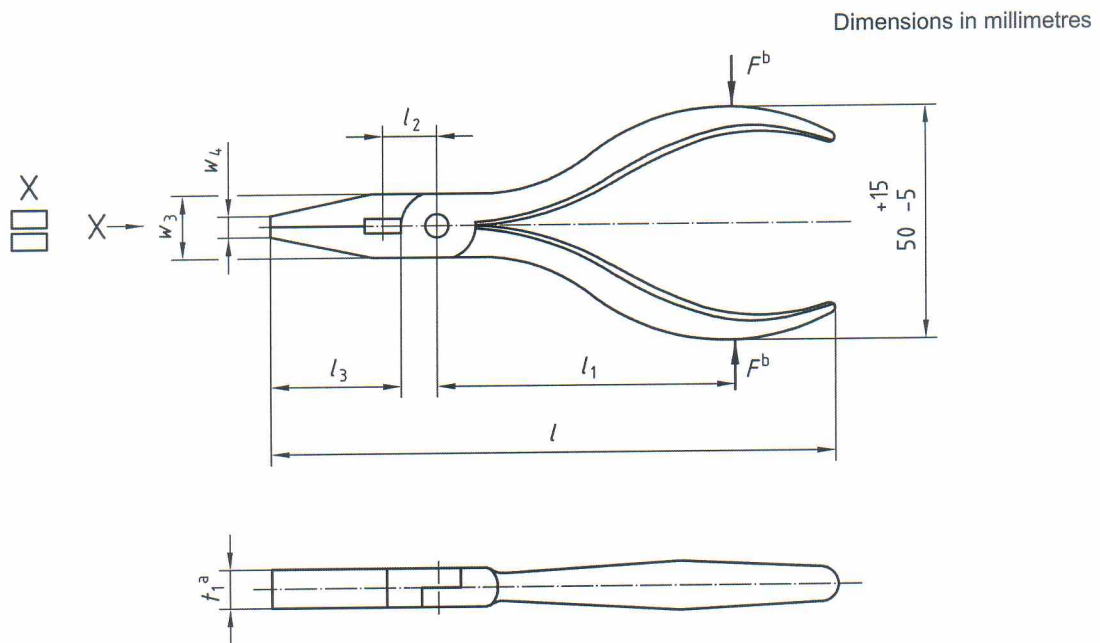

- ^a The head may be tapered over length l_3 .
- ^b F = Load applied in load test or F_1 force applied in cutting test.

Figure 5 — Flat nose pliers with side cutter for medium hard wire

Table 9 — Flat nose pliers with side cutter for medium hard wire, principal dimensions

Dimensions in millimetres

l	l_3	w_3 max.	w_4 max.	t_1 max.
140 ± 7	40 ± 5	16	2,5	9
160 ± 8	$53 \pm 6,3$	19	3,2	10
200 ± 10	80 ± 10	22	5	11

After the load test, the permanent set s shall not exceed the value given in Table 10. If distance l_1 is not suitable for the load test, the formula given in ISO 5744:2004, 4.2 shall be used.

Pliers having a lever ratio differing from the values given in Table 10 shall be checked for compliance using the formula given in ISO 5744:2004, 5.3.2.

Table 10 — Flat nose pliers with side cutter for medium hard wire, dimensions for load and force application, test values

Nominal length	l_1	l_2	Cutting test		Load test	
			Diameter of medium hard test wire	Maximum cutting force	Load	Maximum permanent set
l mm	mm	mm	d^a mm	$F_{1, \max}$ N	F N	s_{\max}^b mm
140	63	12,5	1,6	570	630	1
160	71	14	1,6	570	710	1
200	90	18	1,6	570	900	1

^a Data for medium hard test wire are given in ISO 5744.

^b $s = w_1 - w_2$ (see ISO 5744).

4 Designation

EXAMPLE 1 Round nose pliers, number 203 in accordance with ISO 5742, with a nominal length, l , of 140 mm and short nose (S) are designated as follows:

Round nose pliers 203 - ISO 5745 - 140 - S

EXAMPLE 2 Flat nose pliers, number 201 in accordance with ISO 5742, with a nominal length, l , of 160 mm and long nose (L) are designated as follows:

Flat nose pliers 201 - ISO 5745 - 160 - L

EXAMPLE 3 Snipe nose pliers, number 202 in accordance with ISO 5742, with a nominal length, l , of 180 mm are designated as follows:

Snipe nose pliers 202 - ISO 5745 - 180

DIN ISO 5745:2006-09

EXAMPLE 4 Snipe nose pliers, number 202 in accordance with ISO 5742, with a nominal length, l , of 160 mm and with side cutter (C) are designated as follows:

Snipe nose pliers 202 - ISO 5745 - 160 - C

EXAMPLE 5 Flat nose pliers, number 201 in accordance with ISO 5742, with a nominal length, l , of 140 mm and with side cutter (C) are designated as follows:

Flat nose pliers 201 - ISO 5745 - 140 - C

5 Marking

Marking shall be in accordance with ISO 5743.

Bibliography

- [1] ISO 5742, *Pliers and nippers — Nomenclature*