

DIN ISO 9656

DIN

ICS 25.140.30

Supersedes
DIN ISO 9656:1994-09

**Pliers and nippers for electronics –
Test methods (ISO 9656:2004)
English version of DIN ISO 9656:2006-09**

Elektronikzangen –
Prüfverfahren (ISO 9656:2004)
Englische Fassung DIN ISO 9656:2006-09

Document comprises 9 pages

Contents

	Page
National foreword	2
National Annex NA (informative) Bibliography	3
1 Scope	4
2 Normative references	4
3 Wire cutting test	4
3.1 General	4
3.2 Diagonal and oblique cutting nippers	4
3.3 All other cutting nippers for electronics	5
4 Torsion test for round nose pliers	5
4.1 Test block	5
4.2 Procedure	5
5 Load test for flat nose and snipe nose pliers	7
5.1 Test piece	7
5.2 Procedure	7
6 Hardness test of jaws	8
Bibliography	9

National foreword

This standard has been prepared by Technical Committee ISO/TC 29 “Small tools”, Subcommittee SC 10 “Assembly tools for screws and nuts, pliers and nippers”.

The responsible German body involved in its preparation was the *Normenausschuss Werkzeuge und Spann-
zeuge* (Tools and Clamping Devices Standards Committee), Technical Committee NA 121-09-01 AA *Zangen*.

The DIN Standards corresponding to the International Standards referred to in clause 2 of the ISO Standard are as follows:

IEC 60317-0-1	DIN EN 60317-0-1
ISO 9654	DIN ISO 9654

Amendments

This standard differs from DIN ISO 9656:1994-09 as follows:

- a) The content of the standard has been updated.
- b) The standard has been editorially revised.

Previous editions

DIN ISO 9656: 1994-09

National Annex NA (informative)

Bibliography

DIN EN 60317-0-1, *Specifications for particular types of winding wires — Part 0-1: General requirements — Enamelled round copper wire*

DIN ISO 9654, *Pliers and nippers for electronics — Single-purpose nippers — Cutting nippers*

Pliers and nippers for electronics — Test methods

1 Scope

This International Standard specifies the methods of test for checking the correct functioning of pliers and nippers for electronics.

The test parameters have been specified on the basis of the functional uses of the tools.

2 Normative references

The following referenced documents are indispensable for the application of this document. For dated references, only the edition cited applies. For undated references, the latest edition of the referenced document (including any amendments) applies.

ISO 9654, *Pliers and nippers for electronics — Single-purpose nippers — Cutting nippers*

IEC 60317-0-1, *Specifications for particular types of winding wires — Part 0-1: General requirements — Enamelled round copper wire*

3 Wire cutting test

3.1 General

Cutting nippers for electronics shall cut Cu ETP wire in accordance with IEC 60317-0-1. The range of diameters of the test wire are specified in ISO 9654.

Upon completion of the test, the cutting edges shall show neither visible indentation nor distortion which could affect the cutting performance of the tool. Nor shall the tool show any damage that could affect its further use.

3.2 Diagonal and oblique cutting nippers

3.2.1 Place a straight length of the minimum diameter test wire on a hard, flat, horizontal surface. The wire shall be cut using the point of the jaws with the cutting edge vertical, solely by the application of manual force on the handles.

3.2.2 Place a length of approximately 25 mm of the minimum diameter test wire at any position along the top two-thirds of the cutting edges, measured from the point. The wire shall be cut solely by the application of manual force on the handles.

3.2.3 Diagonal and oblique cutting nippers shall cut the maximum diameter test wire at any position along the cutting edges.

3.3 All other cutting nippers for electronics

Place a length of maximum 25 mm of the minimum diameter test wire at any position along the cutting edges. The wire shall be cut solely by the application of manual force on the handles. The same requirement applies also when using the maximum diameter test wire.

4 Torsion test for round nose pliers

4.1 Test block

The jaws shall be inserted into two 90° V notches in the test block such that the points of the jaws are 3 mm apart and the jaws are clamped over a length of 2 mm from the point (see Figure 1). The test block shall have a hardness of between 40 HRC and 45 HRC.

4.2 Procedure

With the jaws clamped in the test block, and the handles clamped to resist the turning moment, apply sufficient torque, first in a clockwise direction and then in an anti-clockwise direction, to rotate the jaws relative to the handles through the angle α specified in Table 1 appropriate to the type of pliers under test.

Upon completion of the test, the points of the jaws shall show no angular misalignment and the tool shall show no damage that could affect its further use.

Dimensions in millimetres

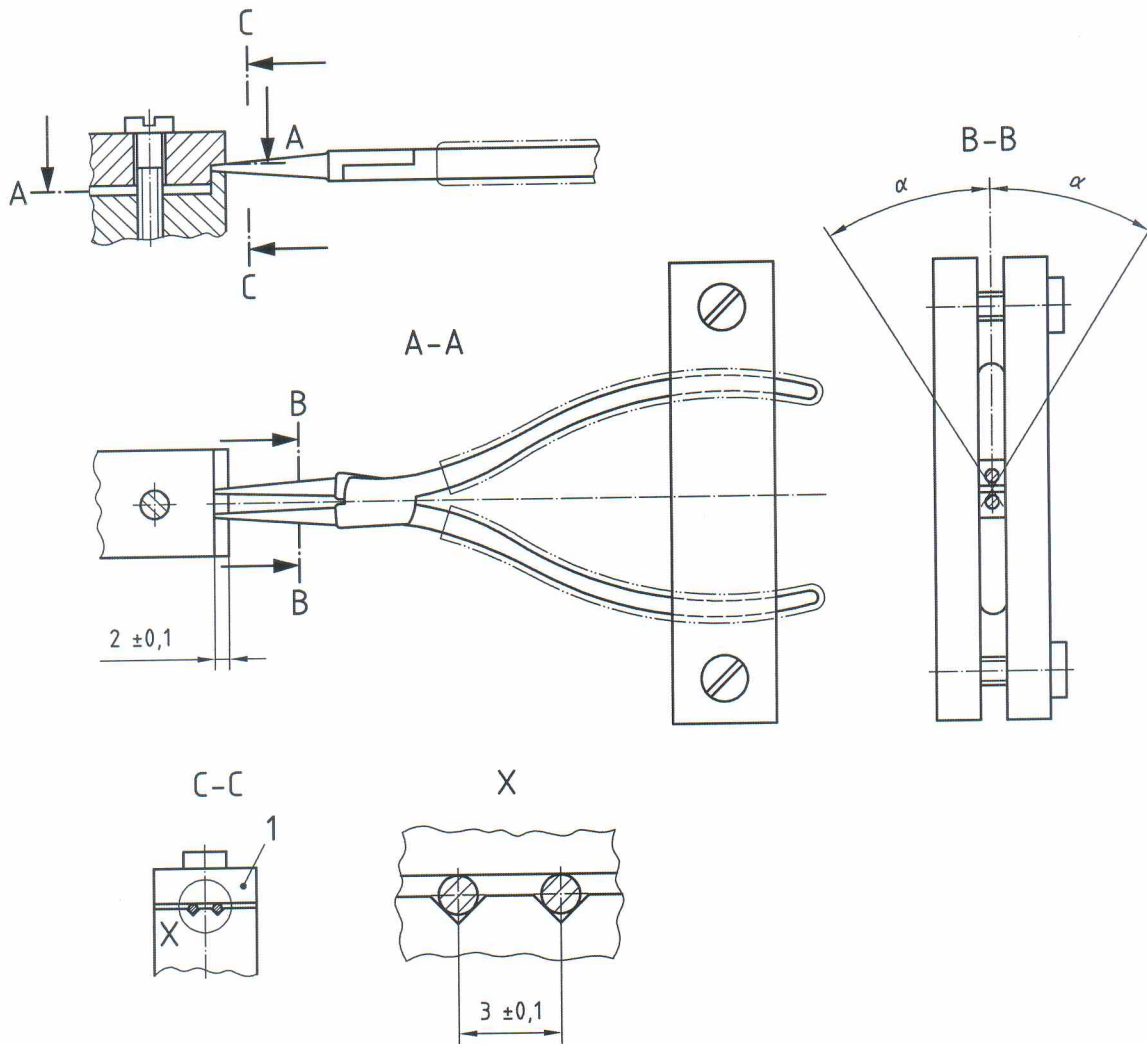

Key

1 test piece

Figure 1 — Example for torsion test for round nose pliers

Table 1 — Torsion values for round nose pliers

Length of jaws	Nominal length <i>l</i> mm	Twist angle α $\pm 3^\circ$
Short jaws	112	20°
	125	
Long jaws	125	25°
	140	

5 Load test for flat nose and snipe nose pliers

5.1 Test piece

Pliers shall grip a $3 \text{ mm} \pm 0,1 \text{ mm}$ thick test piece over a length of $2 \text{ mm} \pm 0,5 \text{ mm}$ measured from the point (see Figure 2). The hardness of the test piece shall be between 30 HRC and 40 HRC.

Dimensions in millimetres

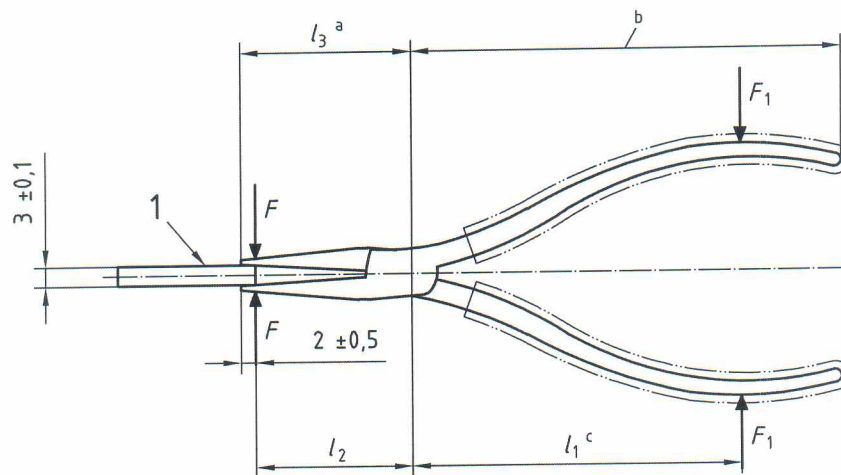

Key

1 test piece

a l_3 is the length from the point of the jaws to the centre of the joint rivet. The test piece shall not be allowed to slip from the jaws.

b Length of handle.

c l_1 is equal to 0,8 times the length of the handle.

Figure 2 — Example for load test for snipe nose pliers and flat nose pliers

5.2 Procedure

Apply the load F_1 (see Figure 2), calculated using the formula given in Tables 2 and 3, appropriate to the type of pliers under test.

Upon completion of the test, the tool shall show no damage that could affect its further use.

Table 2 — Flat nose pliers, load test

Length of jaws	Nominal length <i>l</i> mm	Load test	
		<i>F</i> N	<i>F</i> ₁
Short jaws	112	500	$F_1 = \frac{F \times l_2}{l_1}$
	125		
Long jaws	125	400	
	140		

Table 3 — Snipe nose pliers, load test

Length of jaws	Nominal length <i>l</i> mm	Load test	
		<i>F</i> N	<i>F</i> ₁
Short jaws	112	400	$F_1 = \frac{F \times l_2}{l_1}$
	125		
Long jaws	125	250	
	140		

6 Hardness test of jaws

The hardness shall be measured on the gripping surface or on an adjacent face at a distance of not more than 1 mm from the gripping surface.

On cutting nippers, the hardness of the cutting edges shall be measured not more than 1 mm from the line of the edges.

Bibliography

- [1] ISO 6508-1, *Metallic materials — Rockwell hardness test — Part 1: Test method (scales A, B, C, D, E, F, G, H, K, N, T)*
- [2] ISO 8979, *Pliers and nippers for electronics — Nomenclature*
- [3] ISO 9657, *Pliers and nippers for electronics — General technical requirements*